



PUMPS AUSTRALIA

BETTER • FASTER • EASIER



FLOAT SWITCH

TECHNICAL DATA

MODELS: FS03 | FS05 | FS10 | FS20 | FS30

FLOAT SWITCH 10A

The REEFE® series of float switches are suitable for water pumps and professional plumbing systems automation. Guarantee reliable integration with your pump and control equipment.

APPLICATIONS

- Pump out and tank fill control
- Suitable for use in sewage and stormwater stations
- High level alarm switch
- Run dry protection for low level sensing
- Tank Level Control

FEATURES & BENEFITS

- Neoprene Cables for resistance to chemicals and oils
- Includes easily adjustable counter weight
- Can be configured for close on rise and close on fall operation
- Unique switch design where there is no contact with ball and switch preventing shorts due to corrosion



CODE	MODEL	CABLE LENGTH	FUNCTION
22702	FS03	3m Cable	Double
20630	FS05	5m Cable	Double
20647	FS10	10m Cable	Double
20654	FS20	20m Cable	Double
20661	FS30	30m Cable	Double

POSITION	COMPONENT	MATERIAL
A	Cable	H 07 RN-F
B	Casing	Polypropylene

FEATURE

SPECIFICATIONS

Cable	(FS) H07 RN-F3X1 - Ø7.5MM(2 func.) (FS1) H07 RN-F 3G1 - Ø8.8MM (1 func.)
Casing	Polypropylene
Counterweight Shell	230g (Refer image 1)
Power Supply	Max. 10 (8) A, 240V
Activation Angle	45° Degrees
Depth	Max 10m
Temperature	Max 45C°
Protection Grade	IP68

COUNTERWEIGHT

Image 1



***Not to be used for direct switching to Pumps and High voltage equipment. See models FS105 and FS110 for Direct 240V switching applications.**

COMPONENTS & DIMENSIONS

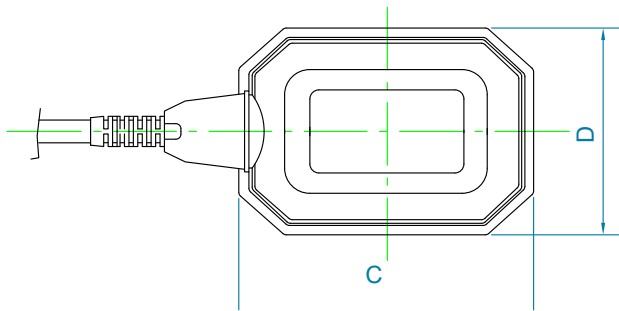
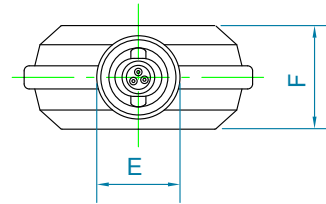
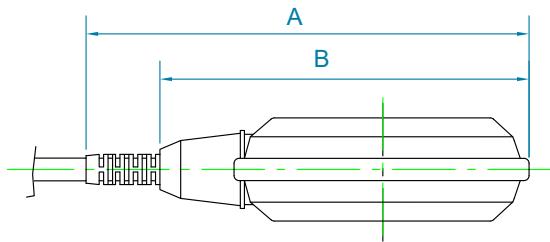

MODEL	FLOAT DIMENSIONS (MM)					
	A	B	C	D	E	F
FS	153	131.5	105	81	31	41

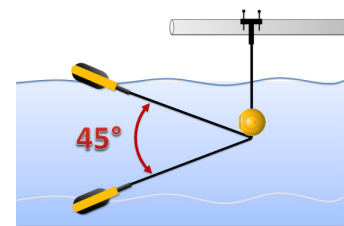
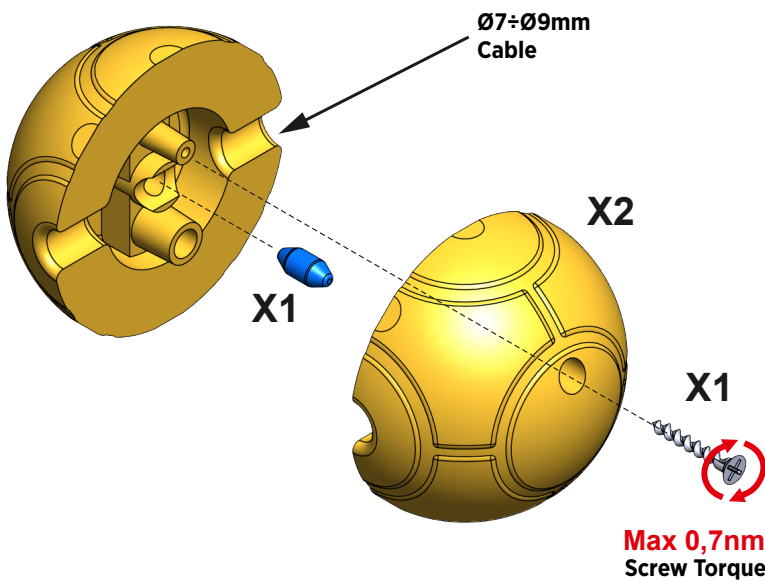

Activation angle: 45°

TECHNICAL GUIDE & INSTRUCTION MANUAL

DO NOT TAMPER WITH THE FLOAT SWITCH. THE MISUSE OF THE FOLLOWING POINTS WILL AUTOMATICALLY CAUSE THE CANCELLATION OF THE WARRANTY OF THE PRODUCT.

1. Before any operation on the float remember to disconnect the power supply from the main power
2. Check that the maximum motor power does not exceed the float's electrical values.
3. In case of cable damage by the final user or installer, the float must be replaced.
4. Do not make any joint on the cable of the float switch, as immersion of such joints could cause short circuits or electrical shocks.

TECHNICAL FEATURES:

Protection Grade: IP68
 Features of automatic action: 1B(micro-disconnections in operation)
 Pollution Degree: 2

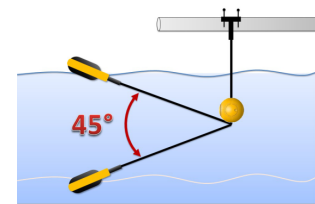

Activation angle: 45°

TERMINAL CONNECTIONS:

The upstream circuit must protect the electric wires from the overcurrent. **WARNING:** lack of protection shall null and void the warranty in the event the float breaks.

- **Mod.01:** Single function - only emptying or only filling (Fig.1.) The grounding wire is always yellow and green. **(FS1 models only)**
- **Mod.02 - Mod.03:** Double function (the fitter can choose the emptying Fig.2 or filling Fig.3 when installing)
- **Emptying: (Fig.2:)** When black and brown wires are used, the circuit opens when float is down and closes when the float is up. Note: the blue/grey wires must be insulated.
- **Filling: (Fig.3)** When black and blue/grey wires are used, the circuit closes when the float is down and opens when the float is up. Note: the brown wire must be insulated.

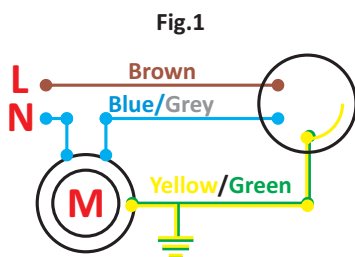

*FS105 & FS110 ONLY

